

## MOTOR FAILS TO TURN ON

- Loose or improper wiring.
- Pump circuit has no power.
- Blown fuse or thermal protection tripped.
- Failed pressure switch.
- Defective motor.

## PUMP FAILS TO TURN OFF AFTER ALL FIXTURES ARE CLOSED

- Punctured diaphragm.
- Discharge line leak.
- Defective pressure switch.
- Insufficient voltage.
- Clogged valves in pump head.

## LOW FLOW AND PRESSURE

- Air leak at pump intake.
- Accumulation of debris inside pump or plumbing.
- Worn pump bearing (possibly accompanied by loud noise).
- Punctured diaphragm.
- Defective motor.

## NOISY

- Check if the mounting feet are compressed too tightly.
- Is the mounting surface flexible? If so, it may be adding noise.
- Check for loose head/screws.
- If the pump is plumbed with rigid pipe, then it may transmit noise more easily.

## ABOUT THE BYPASS

Please consult a professional technician in the case that the bypass needs adjustment. Improper adjustment of the bypass may damage the pump.

The bypass comes preset for optimal operation of the pump. If your application calls for a different setting for the bypass, you may change it yourself. Carefully tighten the screw to increase or loosen the screw to decrease the minimum operational pressure of the bypass.

## CAUTION

Please do follow the instruction manual to install the product. Any action outside what is recommended in this manual may bring damage to the pump. Any inappropriate installation or operation that causes the pump damage is not covered by warranty.

# SEAFLO<sup>®</sup>

## Diaphragm Pump Manual - 41 Series

The 41-Series pump provides high volume water flow. The four chamber high volume design, driven by a heavy-duty motor, produces flow rates up to 4.5GPM. With on-demand switch, the 41-Series pumps are self-priming, and can run dry without damage, performance reliable and low current. SEAFLO also offers a variety of easy connect fittings and filters.

## FEATURES

- 4 chamber diaphragm pump
- Intermittent duty
- Industry standard mounting pattern
- Run dry capable for normal workloads
- Automatic: controlled by pressure switch
- Bypass: reduces cycling
- Self priming
- Quiet Operation
- Thermal protection

## APPLICATIONS

- Yacht/RV/caravan pressurized water system
- Sprayer fixtures (vehicle-mounted sprayers, electric sprayers)
- Cleaning machines, humidifier, water purification, medical apparatus
- Food beverage filling & liquid transfer
- Solar water system
- Any other pressurization system

## INSTALLATION

### Materials

- 1 diaphragm pump with related accessories
- 2 (at least) pieces of flexible, reinforced hose piping, with collapsing strength of twice the inlet collapsing pressure( hose must be minimum 3/4" ID )
- 4 stainless steel hose clamps and screws
- 4 screws to fasten the pump to the mounting surface
- 1 electrical cutoff switch
- 1 fuse
- 1 screwdriver
- 1 strong cutting implement for tubing
- (if desired) Teflon tape or sealant

## Setup

- The pump may be mounted in any position. If mounted vertically, the pump head should be in the down position to avoid leakage into the motor casing in the event of a malfunction.
- Secure the feet, but do not compress them. Overtightening the securing screws may reduce their ability to dissipate noise and vibration.
- Intake hose must be minimum 3/4" (19 mm) ID reinforced hose. Main distribution line from pump outlet should also be 3/4" (19 mm) ID with branch and individual supply lines to outlets no smaller than 3/8" (10 mm).
- Plumb the system using high pressure (2x pump rating), braided, flexible tubing to minimize vibration/ noise.
- Do not apply inlet pressure in excess of 30 psi. In general, try to avoid any inlet pressure completely.
- Avoid any kinks or fittings which could cause excessive restrictions.
- Strainer should be attached to the inlet side.
- The fittings must be secured to avoid leakage.
- Use clamps at both ends of hose to prevent air leaks into the water line.
- If a check valve is installed in the plumbing, it must have a cracking pressure of no more than 2 psi.
- If applying a sealer or plumbing tape, be careful to not overtighten, as they may be sucked into pump.
- This pump should be wired on its own dedicated circuit. Connect the positive lead (red) to the positive terminal of your battery and the negative wire (black) to the negative terminal of your battery.
- In an easily accessible location, install a switch to control electricity to the pump. Turn the pump off when not used for extended periods or when the tank is empty.
- The electrical circuit should be protected with an over-current protection device (fuse) in the positive lead. This pump requires a 30 amp fuse.
- The pump circuit should not include any other electrical loads.
- As the water supply pump is non-essential, reference the wire chart under the electrical information. Be sure to have the correct wire sizing for the length of wire you are using.
- After installation, check the voltage at the pump motor. Voltage should be checked when pump is operating. Full voltage must be available at the pump motor at all times.

## Notes

- Flexible potable water hose or PEX tubing is recommended instead of rigid piping at pump. If you choose to use rigid piping, provide a short length of hose between pipe and the pump to avoid noise and vibration.
- We do not recommend the use of metal fittings. When possible, use the provided plastic fittings.
- Do not adjust the bypass personally without the help of technician.
- Lack of sanitizing and maintenance is one of the main reasons of under performance of the pump. Please do maintenance and winterize the pump at appropriate times, especially before and after a period of storage.
- All 115 VAC and 230 VAC pump motors and systems, MUST be ground per local and state electrical codes.

115 AC	BLACK(common),WHITE(neutral),GREEN(ground)	#16 AWG C-UL-TEW / UL 1015
230 AC	BROWN(common),BLUE(neutral),GRN/YELL(ground)	(or heavier) [Mm <sup>2</sup> ]

## ELECTRICAL INFORMATION

Ft. (M)	AWG (MM <sup>2</sup> )
0-20 (0-6)	14 AWG
20-30 (6-9)	12 AWG
30-65 (9-19)	10 AWG
65-100 (19-30)	8 AWG

## REPAIR KITS

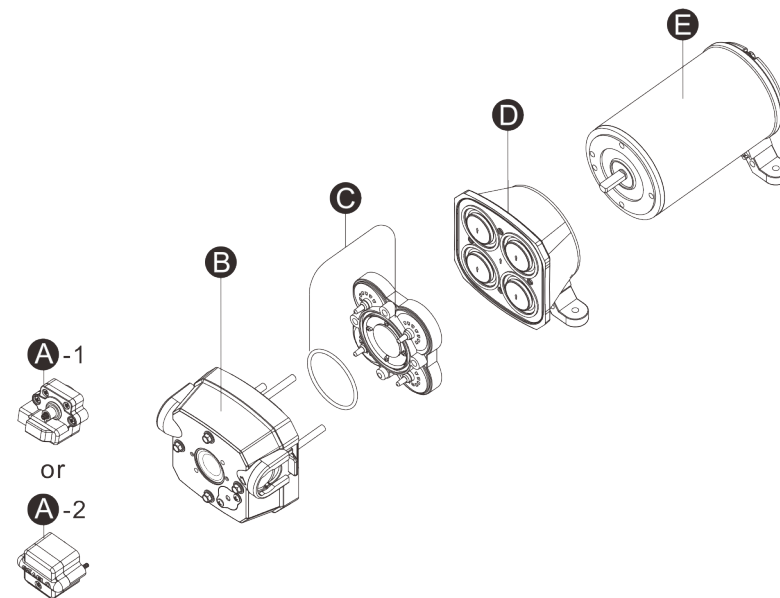

Key	Description	Quantity
A-1 or A-2	Pressure switch	1
B	Pump Head Assembly	1
C	Valve Assembly	1
D	Diaphragm Assembly	1
E	Motor Assembly	1

## TROUBLESHOOTING

### PULSATING FLOW– PUMP CYCLES ON AND OFF

- Check lines for kinks.
- Plumbing lines or fittings may be too small.
- Clean faucets and filters.
- Check fitting tightness for air leaks.

### FAILURE TO PRIME BUT MOTOR OPERATES - NO PUMP DISCHARGE

- Restricted intake or discharge line.
- Air leak in intake line.
- Punctured pump diaphragm.
- Initial amp supply is not enough to sufficiently start the motor.
- Debris clogged in the valves.
- Crack in pump housing.